

MSI-3700 SPECIFICATIONS

MSI-3700 Magnum Plus Scale (carriage attachment)

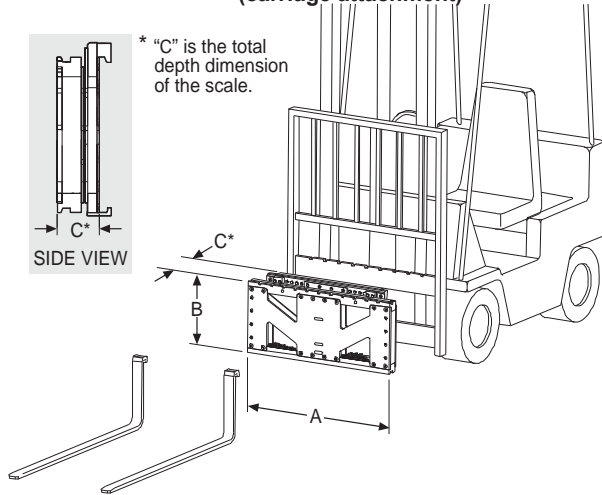

MSI-3650 Digital Weight Indicator

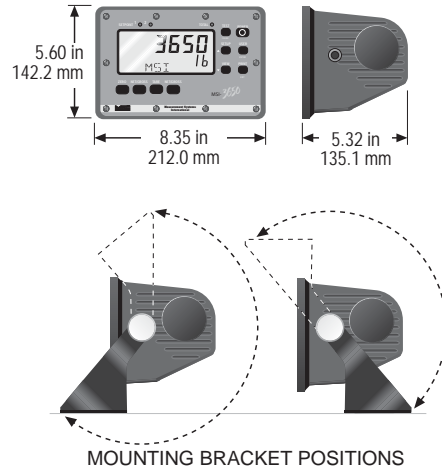

CAPACITY	RESOLUTION	ITA CARRIAGE CLASS	A	DIMENSIONS B	C	SHIPPING WEIGHT
5,000 lb 2,500 kg	2 lb 1 kg	II II	36.0 in 914.4 mm	16.0 in 406.4 mm	4.35 in 110.49 mm	180.5 lb 81.87 kg
8,000 lb 4,000 kg	2 lb 1 kg	III III	42.0 in 1066.8 mm	20.0 in 508.0 mm	5.0 in 127.0 mm	570 lb 259 kg
10,000 lb 5,000 kg	5 lb 2 kg	III III	48.0 in 1219.2 mm	20.0 in 508.0 mm	5.0 in 127.0 mm	670 lb 304 kg

For higher capacity units or bar-mount style trucks, consult factory.

Standard System Specifications

Scale/Carriage Assembly

Rated capacity: See above chart

Accuracy: 0.1% of rated capacity

Safe Overload: 200%

Ultimate Overload: 500%

Digital Indicator (MSI-3650)

Power:

- 10 to 56 VDC

Display:

- 6 digit, 0.90 in (23 mm) high numeric LCD (weight display)
- 8 digit, 0.45 in (11 mm) high alphanumeric LCD (message display)
- 21 segment analog bar graph for level indications with NTEP option
- LED annunciator for Totalizing and Set Point indication
- Photocell activated backlighting

Functions:

- Power: On/Off
- Zero: zero out residual weight
- Net/Gross: switch between Net (tared) and Gross weight
- Tare: tare out empty container weight and indicate Net weights
- Total: accumulate weighments in register manually or automatically
- ViewΣ: displays accumulated weighments in registers
- Print: digital output to external printer
- User: program user defined functions
- Test: display and function test
- Setup: for selection of programming functions and features

Programmable Features:

- Auto or Manual Tare entry
- Auto or Manual Totalizing
- 12 programmable ID codes (more with expanded memory option)
- Lock mode for preventing unauthorized program changes
- Pounds/kilograms mode selectable
- Digital calibration

Enclosure:

- NEMA 4, IP65 alodined and powder coated cast aluminum

Operating Temperature:

- 14° to 140°F (-10° to 60°C)

Product Options

- Class III carriage attachment 8,000 lb x 2 lb (4,000 kg x 1 kg)
- Class III carriage attachment 10,000 lb x 5 lb (5,000 kg x 2 kg)
- NTEP approved for legal for trade installations only available with Class II attachment. Maximum capacity of 5,000 lb x 5 lb (2,500 kg x 2 kg)
- Expanded ID Memory up to 240 ID Codes
- RS-232 data output with real time clock and full output formatting
- Tape printer with truck mounting bracket (requires RS-232 option)
- Cable retracting and storage assembly kit with 200 in maximum lift height (contact factory for specifications)
- Substitute standard indicator with MSI-3750 (contact factory for specifications)
- Wireless RF data transfer



Specifications subject to change without notice.

PUB.123-03-90F Printed in U.S.A.

© 2009 by Measurement Systems International, Inc.



14240 Interurban Avenue South STE.200

Seattle, Washington 98168-4661 U.S.A.

Phone: 206-433-0199 • Fax: 206-244-8470

Web: www.msiscal.com • Email: info@msiscal.com